

Certification and Approval

Industrial Luminaire

Bulk head fitting suitable for non hazardous industrial and commercial applications
 Available in a range of lamp formats including energy efficient PL's Emergency version
 with integral battery available with PL lamps (not supplied) Ingress Protection IP 65

Features Options

Hinged lens opening
 Rapid lamp and control gear access
 Even light distribution

Lamp source variants
 Power factor correction
 Various lamp options available

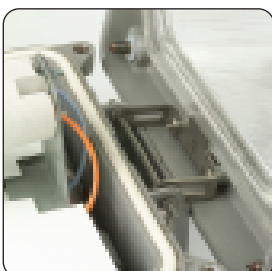
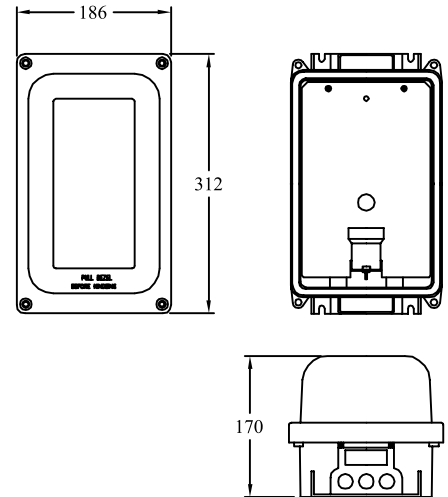

Hinged lens opening



Screwed bezel fixings



Integral mounting feet

Technical Data

Supply Voltage	230v 50Hz standard..
Operating Temperature	-20°C to +25°C standard supply subject to ambient temperature requirements.
Control Gear	Integral within the luminaire and optional power factor correction. Emergency version available for PL lamps
Lamp Options	Elliptical: 70w SON 80w HPMV 200w GLS PL 28w
Cable Entries	2 x M20 Threaded entries at one end (1 plugged).
Terminals	2 wire and earth. Cable size 4mm ² max
Mounting Facility	4 cast in fixing lugs to take M8 screws.
Access	Unscrew retaining screws to open hinged lens.
Material	Die cast aluminium body and bezel and borosilicate glass lens
Finish	Grey powder coated or 2 Pack epoxy paint on primed surface. Additional costs for non standard colours.
Weight	70w and 80w 8.0Kgs 200w 6.5Kgs PL 7.0 Kgs PL emergency 8.0 Kgs
Features	Rapid lamp and control gear access Even light distribution Various lamp options available